

EE-559 – Deep learning

3.6. Back-propagation

François Fleuret

<https://fleuret.org/ee559/>

Fri Mar 1 09:42:35 UTC 2019



We want to train an MLP by minimizing a loss over the training set

$$\mathcal{L}(w, b) = \sum_n \ell(f(x_n; w, b), y_n).$$

To use gradient descent, we need the expression of the gradient of the per-sample loss $\ell_n = \ell(f(x_n; w, b), y_n)$ with respect to the parameters, e.g.

$$\frac{\partial \ell_n}{\partial w_{i,j}^{(l)}} \quad \text{and} \quad \frac{\partial \ell_n}{\partial b_i^{(l)}}.$$

For clarity, we consider a single training sample x , and introduce $s^{(1)}, \dots, s^{(L)}$ as the summations before activation functions.

$$x^{(0)} = x \xrightarrow{w^{(1)}, b^{(1)}} s^{(1)} \xrightarrow{\sigma} x^{(1)} \xrightarrow{w^{(2)}, b^{(2)}} s^{(2)} \xrightarrow{\sigma} \dots \xrightarrow{w^{(L)}, b^{(L)}} s^{(L)} \xrightarrow{\sigma} x^{(L)} = f(x; w, b).$$

Formally we set $x^{(0)} = x$,

$$\forall l = 1, \dots, L, \begin{cases} s^{(l)} = w^{(l)}x^{(l-1)} + b^{(l)} \\ x^{(l)} = \sigma(s^{(l)}), \end{cases}$$

and we set the output of the network as $f(x; w, b) = x^{(L)}$.

This is the forward pass.

The core principle of the back-propagation algorithm is the “chain rule” from differential calculus:

$$(g \circ f)' = (g' \circ f)f'.$$

The linear approximation of a composition of mappings is the product of their individual linear approximations.

This generalizes to longer compositions and higher dimensions

$$J_{f_N \circ f_{N-1} \circ \dots \circ f_1}(x) = J_{f_1}(x) J_{f_2}(f_1(x)) J_{f_3}(f_2(f_1(x))) \dots J_{f_N}(f_{N-1}(\dots(x)))$$

where $J_f(x)$ is the Jacobian of f at x , that is the matrix of the linear approximation of f in the neighborhood of x .

$$x^{(l-1)} \xrightarrow{w^{(l)}, b^{(l)}} s^{(l)} \xrightarrow{\sigma} x^{(l)}$$

Since $s_i^{(l)}$ influences ℓ only through $x_i^{(l)}$ with

$$x_i^{(l)} = \sigma(s_i^{(l)}),$$

we have

$$\frac{\partial \ell}{\partial s_i^{(l)}} = \frac{\partial \ell}{\partial x_i^{(l)}} \frac{\partial x_i^{(l)}}{\partial s_i^{(l)}} = \frac{\partial \ell}{\partial x_i^{(l)}} \sigma'(s_i^{(l)}),$$

And since $x_j^{(l-1)}$ influences ℓ only through the $s_i^{(l)}$ with

$$s_i^{(l)} = \sum_j w_{i,j}^{(l)} x_j^{(l-1)} + b_i^{(l)},$$

we have

$$\frac{\partial \ell}{\partial x_j^{(l-1)}} = \sum_i \frac{\partial \ell}{\partial s_i^{(l)}} \frac{\partial s_i^{(l)}}{\partial x_j^{(l-1)}} = \sum_i \frac{\partial \ell}{\partial s_i^{(l)}} w_{i,j}^{(l)}.$$

$$x^{(l-1)} \xrightarrow{w^{(l)}, b^{(l)}} s^{(l)} \xrightarrow{\sigma} x^{(l)}$$

Since $w_{i,j}^{(l)}$ and $b_i^{(l)}$ influences ℓ only through $s_i^{(l)}$ with

$$s_i^{(l)} = \sum_j w_{i,j}^{(l)} x_j^{(l-1)} + b_i^{(l)},$$

we have

$$\begin{aligned} \frac{\partial \ell}{\partial w_{i,j}^{(l)}} &= \frac{\partial \ell}{\partial s_i^{(l)}} \frac{\partial s_i^{(l)}}{\partial w_{i,j}^{(l)}} = \frac{\partial \ell}{\partial s_i^{(l)}} x_j^{(l-1)}, \\ \frac{\partial \ell}{\partial b_i^{(l)}} &= \frac{\partial \ell}{\partial s_i^{(l)}}. \end{aligned}$$

To summarize: we can compute $\frac{\partial \ell}{\partial x_i^{(l)}}$ from the definition of ℓ , and recursively **propagate backward** the derivatives of the loss w.r.t the activations with

$$\frac{\partial \ell}{\partial s_i^{(l)}} = \frac{\partial \ell}{\partial x_i^{(l)}} \sigma'(s_i^{(l)})$$

and

$$\frac{\partial \ell}{\partial x_j^{(l-1)}} = \sum_i \frac{\partial \ell}{\partial s_i^{(l)}} w_{i,j}^{(l)}.$$

And then compute the derivatives w.r.t the parameters with

$$\frac{\partial \ell}{\partial w_{i,j}^{(l)}} = \frac{\partial \ell}{\partial s_i^{(l)}} x_j^{(l-1)},$$

and

$$\frac{\partial \ell}{\partial b_i^{(l)}} = \frac{\partial \ell}{\partial s_i^{(l)}}.$$

To write all this in tensorial form, if $\psi : \mathbb{R}^N \rightarrow \mathbb{R}^M$, we will use the standard Jacobian notation

$$\left[\frac{\partial \psi}{\partial \mathbf{x}} \right] = \begin{pmatrix} \frac{\partial \psi_1}{\partial x_1} & \cdots & \frac{\partial \psi_1}{\partial x_N} \\ \vdots & \ddots & \vdots \\ \frac{\partial \psi_M}{\partial x_1} & \cdots & \frac{\partial \psi_M}{\partial x_N} \end{pmatrix},$$

and if $\psi : \mathbb{R}^{N \times M} \rightarrow \mathbb{R}$, we will use the compact notation, also tensorial

$$\left[\left[\frac{\partial \psi}{\partial \mathbf{w}} \right] \right] = \begin{pmatrix} \frac{\partial \psi}{\partial w_{1,1}} & \cdots & \frac{\partial \psi}{\partial w_{1,M}} \\ \vdots & \ddots & \vdots \\ \frac{\partial \psi}{\partial w_{N,1}} & \cdots & \frac{\partial \psi}{\partial w_{N,M}} \end{pmatrix}.$$

A standard notation (that we do not use here) is

$$\left[\frac{\partial \ell}{\partial \mathbf{x}^{(l)}} \right] = \nabla_{\mathbf{x}^{(l)}} \ell \quad \left[\frac{\partial \ell}{\partial \mathbf{s}^{(l)}} \right] = \nabla_{\mathbf{s}^{(l)}} \ell \quad \left[\frac{\partial \ell}{\partial \mathbf{b}^{(l)}} \right] = \nabla_{\mathbf{b}^{(l)}} \ell \quad \left[\left[\frac{\partial \ell}{\partial \mathbf{w}^{(l)}} \right] \right] = \nabla_{\mathbf{w}^{(l)}} \ell.$$

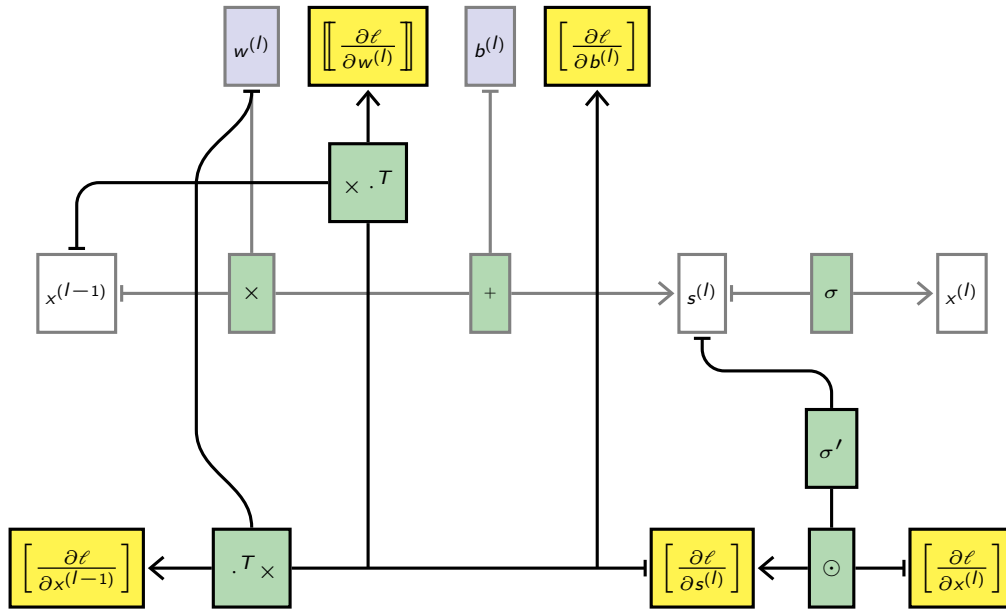

Forward pass

Compute the activations.

$$x^{(0)} = x, \quad \forall l = 1, \dots, L, \quad \begin{cases} s^{(l)} = w^{(l)} x^{(l-1)} + b^{(l)} \\ x^{(l)} = \sigma(s^{(l)}) \end{cases}$$

Backward pass

Compute the derivatives of the loss wrt the activations.

$$\begin{cases} \left[\frac{\partial \ell}{\partial x^{(L)}} \right] \text{ from the definition of } \ell & \left[\frac{\partial \ell}{\partial s^{(l)}} \right] = \left[\frac{\partial \ell}{\partial x^{(l)}} \right] \odot \sigma'(s^{(l)}) \\ \text{if } l < L, \left[\frac{\partial \ell}{\partial x^{(l)}} \right] = (w^{(l+1)})^T \left[\frac{\partial \ell}{\partial s^{(l+1)}} \right] & \end{cases}$$

Compute the derivatives of the loss wrt the parameters.

$$\left[\frac{\partial \ell}{\partial w^{(l)}} \right] = \left[\frac{\partial \ell}{\partial s^{(l)}} \right] (x^{(l-1)})^T \quad \left[\frac{\partial \ell}{\partial b^{(l)}} \right] = \left[\frac{\partial \ell}{\partial s^{(l)}} \right].$$

Gradient step

Update the parameters.

$$w^{(l)} \leftarrow w^{(l)} - \eta \left[\frac{\partial \ell}{\partial w^{(l)}} \right] \quad b^{(l)} \leftarrow b^{(l)} - \eta \left[\frac{\partial \ell}{\partial b^{(l)}} \right]$$

In spite of its hairy formalization, the backward pass is a simple algorithm: apply the chain rule again and again.

As for the forward pass, it can be expressed in tensorial form. Heavy computation is concentrated in linear operations, and all the non-linearities go into component-wise operations.

Regarding computation, since the costly operation for the forward pass is

$$\mathbf{s}^{(l)} = \mathbf{w}^{(l)} \mathbf{x}^{(l-1)} + \mathbf{b}^{(l)}$$

and for the backward

$$\left[\frac{\partial \ell}{\partial \mathbf{x}^{(l)}} \right] = \left(\mathbf{w}^{(l+1)} \right)^T \left[\frac{\partial \ell}{\partial \mathbf{s}^{(l+1)}} \right]$$

and

$$\left[\frac{\partial \ell}{\partial \mathbf{w}^{(l)}} \right] = \left[\frac{\partial \ell}{\partial \mathbf{s}^{(l)}} \right] \left(\mathbf{x}^{(l-1)} \right)^T,$$

the rule of thumb is that the backward pass is twice more expensive than the forward one.