

# Abstraction is Reduction: A Unified Theory of Computation, Meaning, and Physics

Why hiding detail is not a retreat from implementation,  
but the completion of computation.

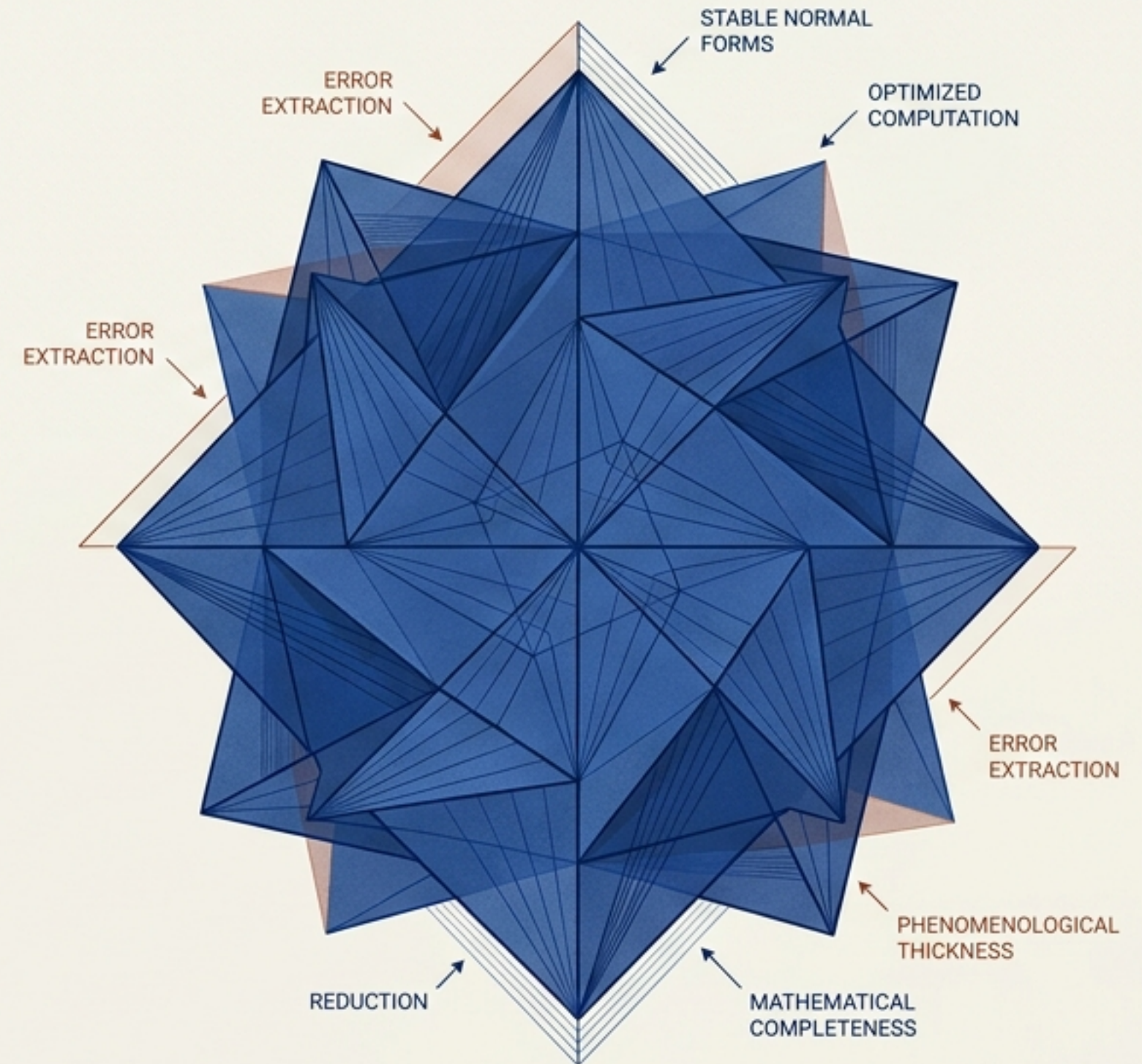
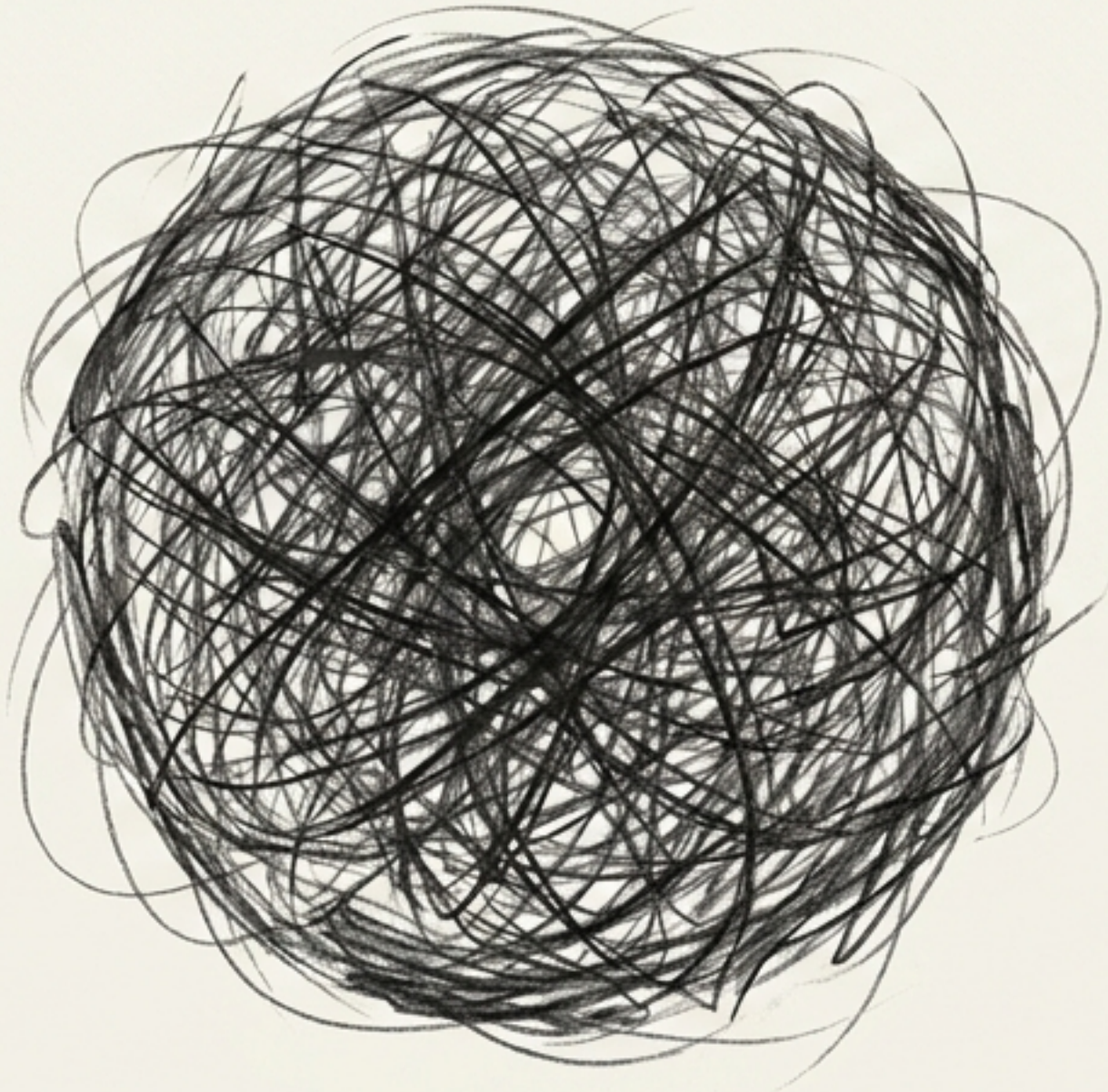

# The surface becomes available only because the depth has been executed.

## The Pedagogical Myth

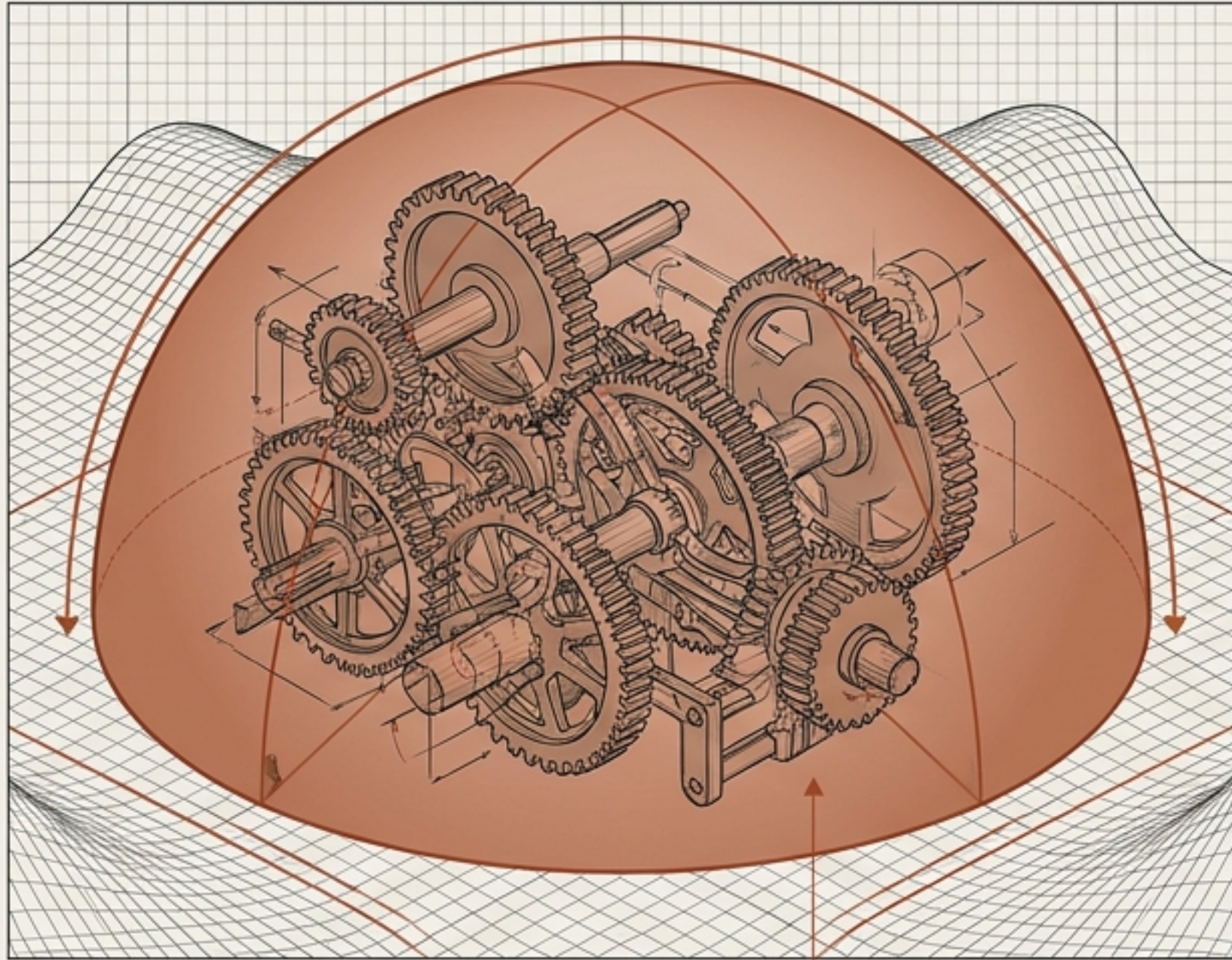

Abstraction is concealment. We put a conceptual shell around unevaluated complexity to distance ourselves from the substrate.

Core Insight: A system only becomes abstractable when its internal obligations are fully discharged and stabilized.

## The Structural Reality

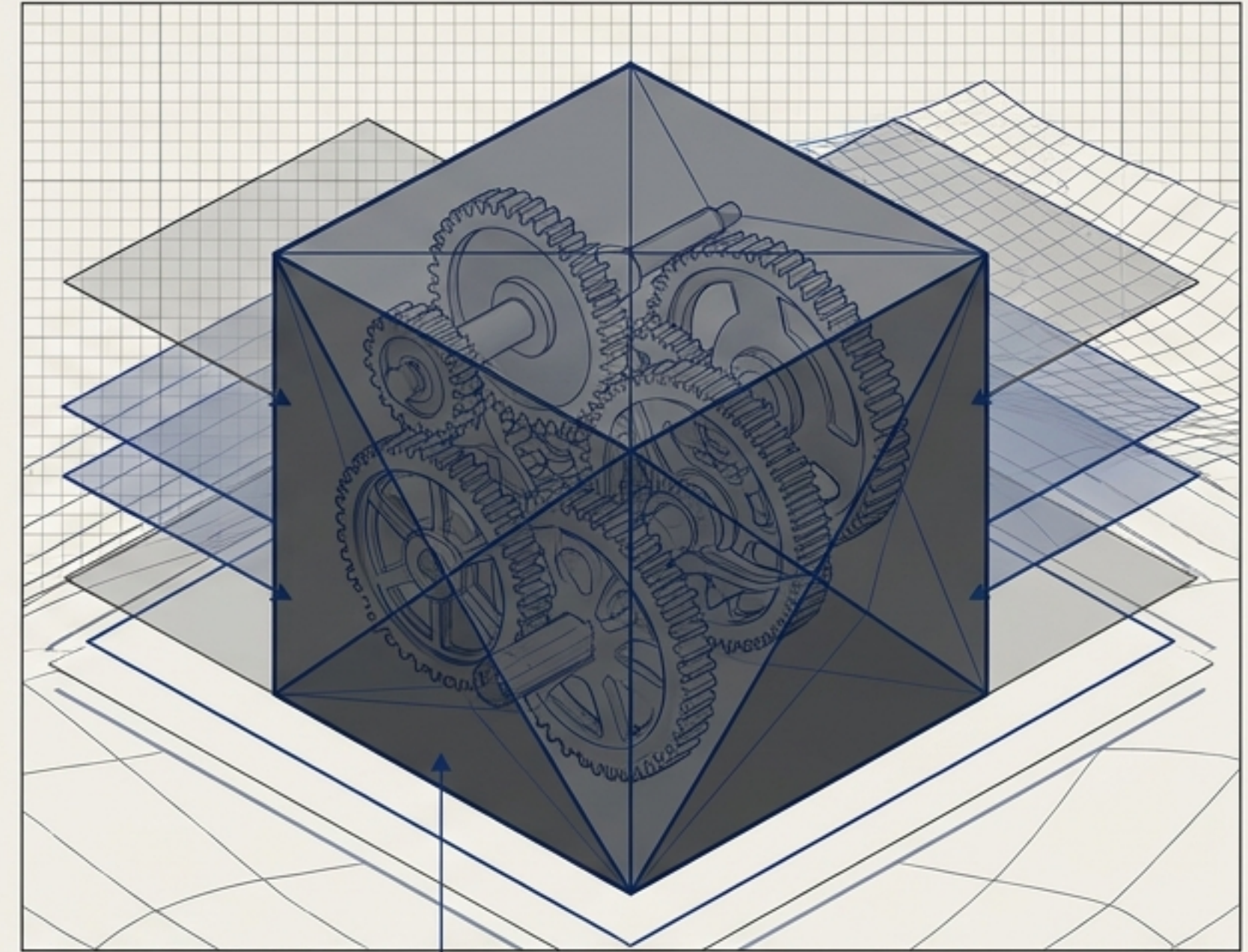

Abstraction is innermost reduction. It is an evaluative step. To abstract is to execute; to hide is to finish a proof.

# The Universal Dictionary of Reduction.

	Untyped Lambda Calculus	Functional Programming	Null Convention Logic (Hardware)	Category Theory	Curry-Howard Correspondence
Inner Complexity	Beta-reduction (resolving the deepest dependency)	Evaluating the Function Body	Dual-rail asynchronous fluctuation	Internal object constitution	Logical detours / Lemmas
Stable Abstraction	The Normal Form	The Type Signature (Behavioral Contract)	Determinate Boolean Value	Functorial Morphisms (Structural roles)	Cut-elimination / Normalized Proof

Across logic, hardware, and category theory, the invariant pattern holds: abstraction is the mathematical marker of successful completion.

# The geometry of doing your homework is a substrate-independent computation.

**Step 1:** Identify the innermost scope.

$$(2 + 3) \times 4$$

The semi-permeable membrane.  
This is the redex.

**Step 2:** Evaluate & Collapse.  
The internal complexity is discharged into a normal form.

$$5 \times 4$$

**Step 3:** Substitute & Ascend.  
The abstracted value now participates in the outer structure.

$$20$$

## BEDMAS / PEMDAS as a Reduction Strategy

Algebra is not mere symbol manipulation. The student acts as a parser, interpreter, and compiler, systematically eliminating degrees of freedom until only a canonical form remains.

Algebra - value a neonality and nopical form remains.

# Ontology as Affordance: Identity is relational, not intrinsic.

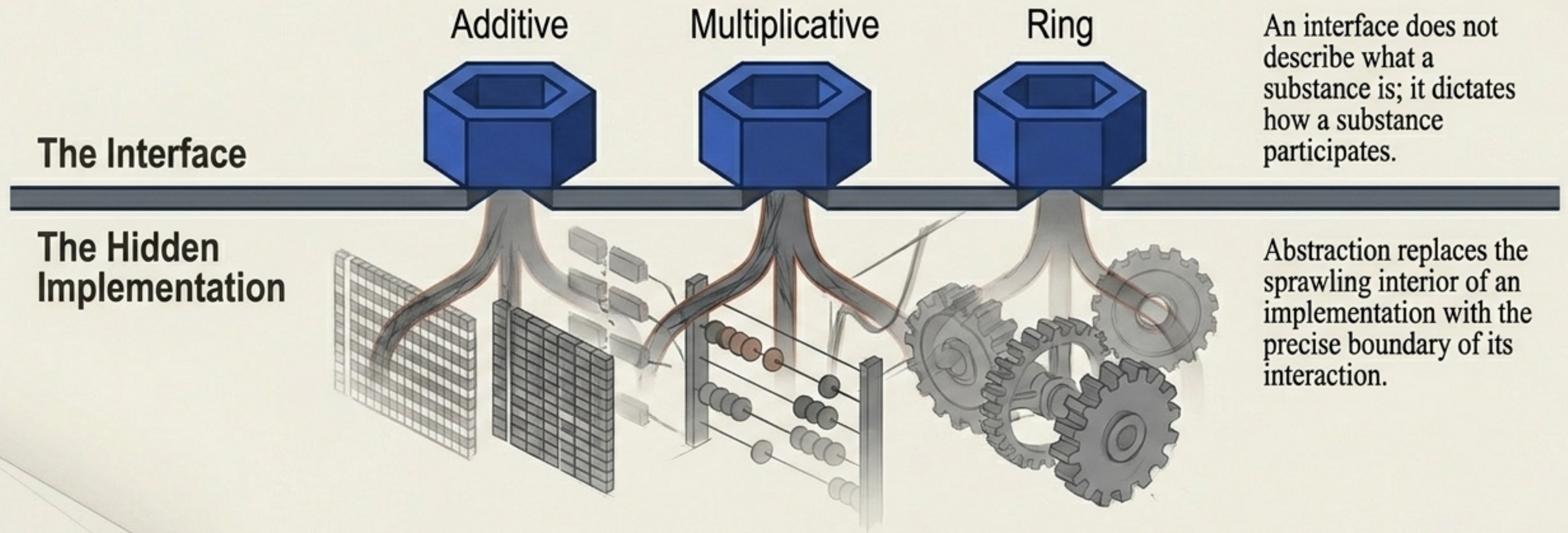

**Insight: To be is to participate through an interface.**

# The Anti-Abstraction: Where computational reduction thins, phenomenology thickens.

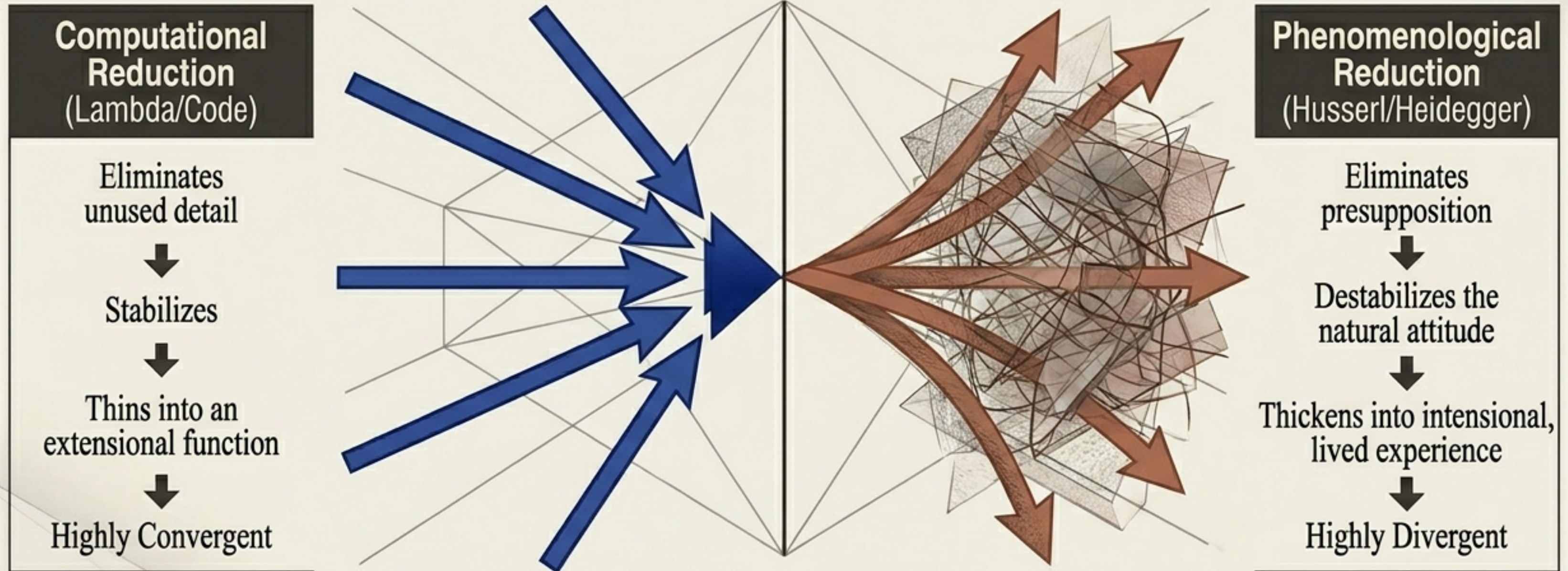

Synthesis Note: Phenomenology is not a model of abstraction; it is its precise antithesis. It is a method for recovering the exact experiential depth that computational abstraction meticulously removes.

# The Ethics of Reduction: When abstraction becomes extraction.

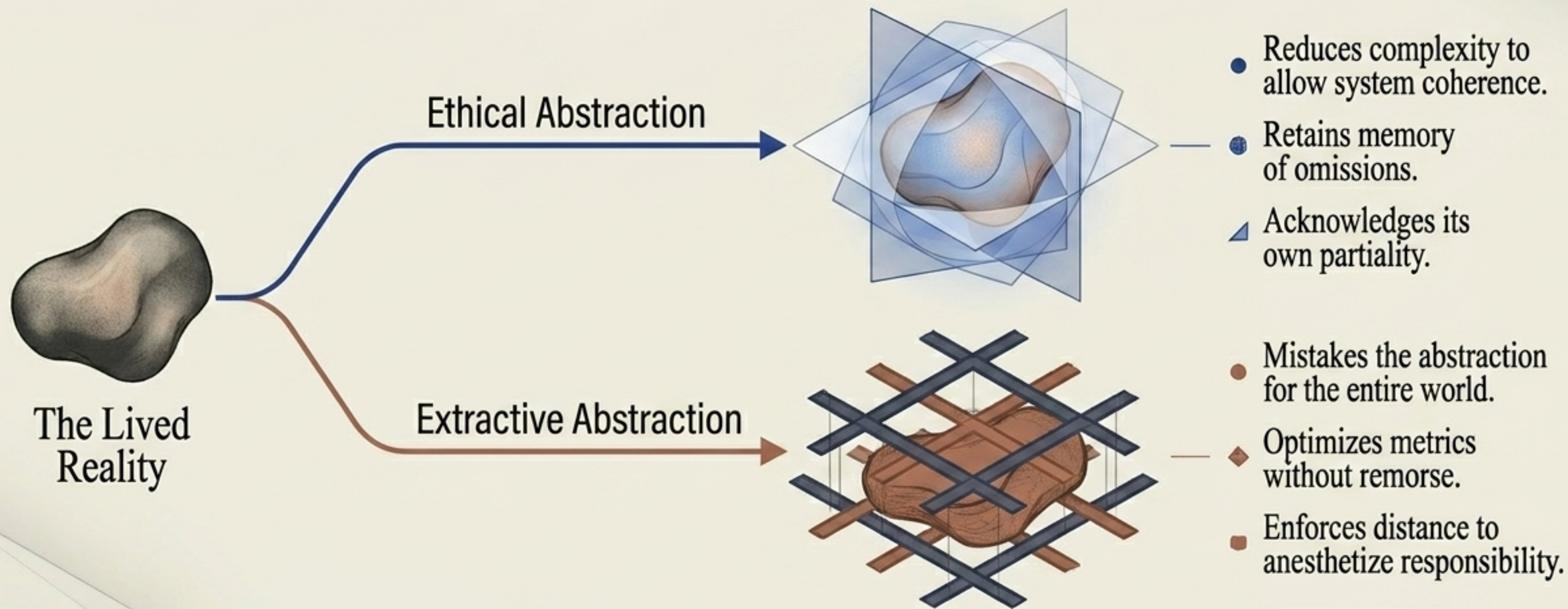

**Core Warning:** Extraction is reduction without humility. The crime is not the abstraction itself, but the assumption that the abstraction is sufficient for existence.

# The Predictive Self is a hierarchy of active abstractions.

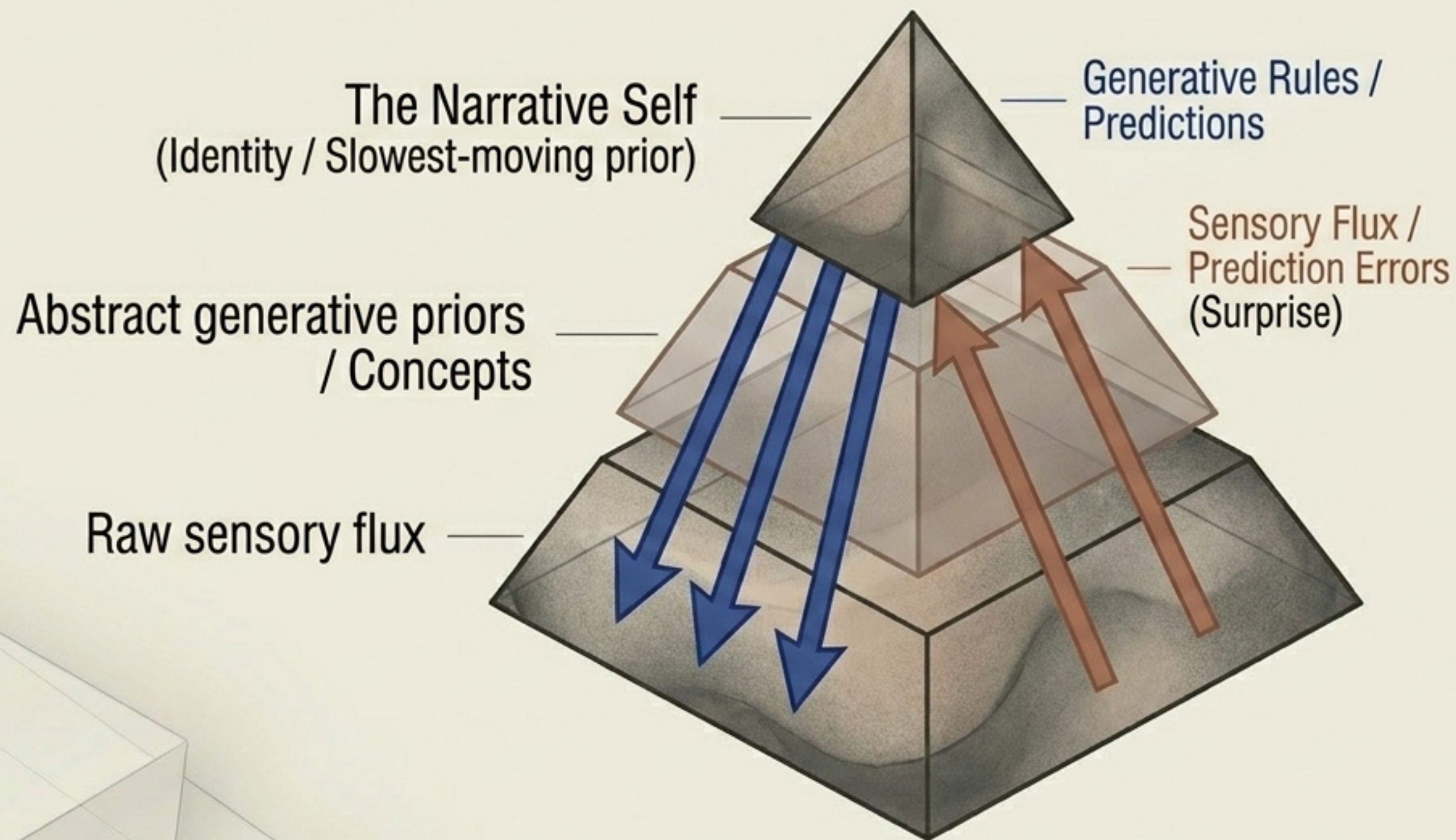

**Key Insight:** Identity is not a memory. It is a generative model designed to minimize long-term free energy.

The self is the symmetry an agent imposes on its own prediction errors to maintain coherence in a chaotic world.

# Belief as a geometric manifold: Inference is differential geometry.

**Compression**  
(The Geometry):  
The internal  
geometry of  
representation.  
Discarding noise  
to retain structure.

**Surprise (The Curvature):**  
Prediction error is a geometric  
misalignment between the  
internal representation and  
reality.

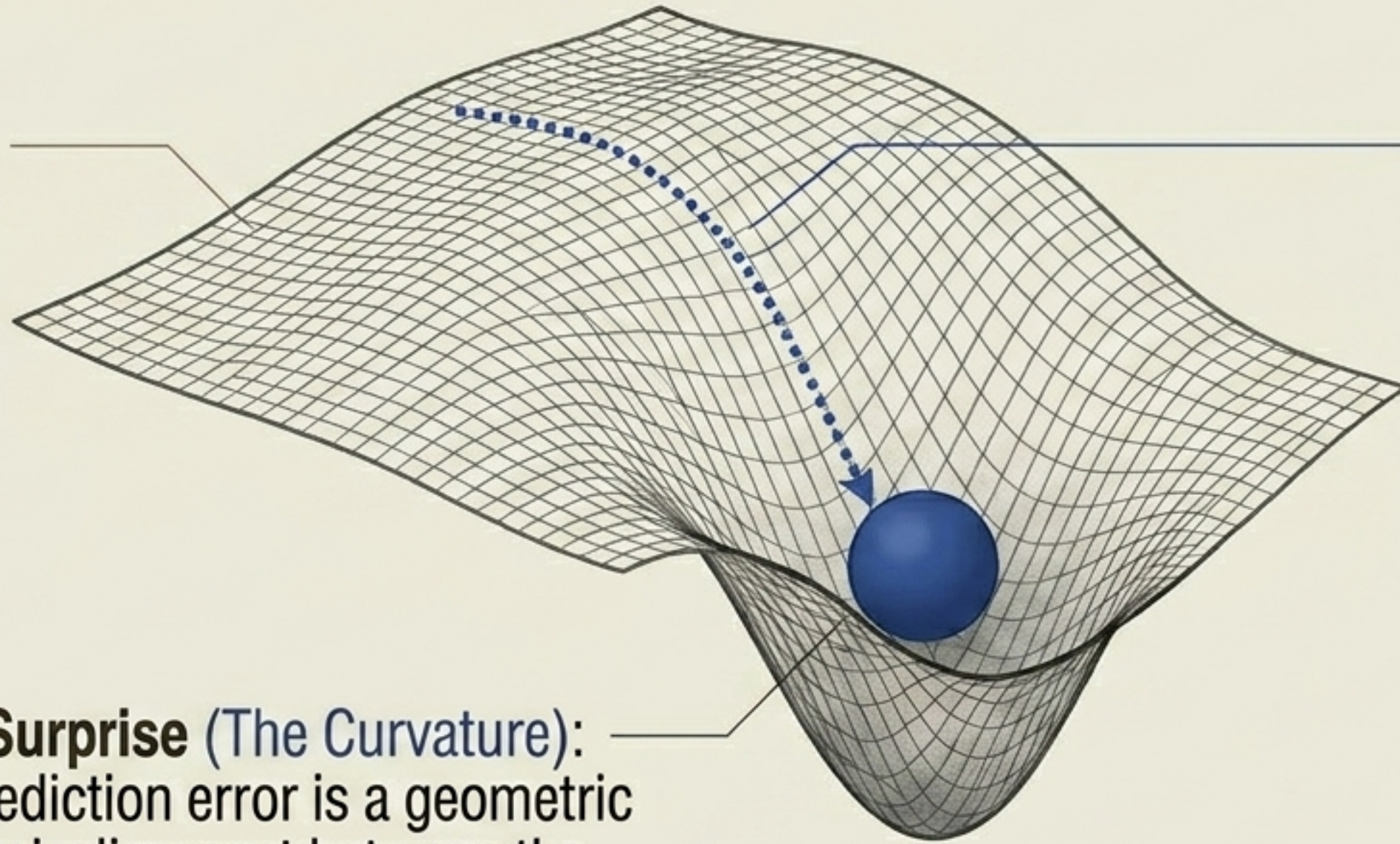

**Belief Update**  
(The Descent):  
A continuous  
geodesic path  
across the  
semantic manifold.  
Beliefs don't  
jump—they flow  
down gradients of  
free energy.

# Markov Boundaries: The semi-permeable membranes of meaning.

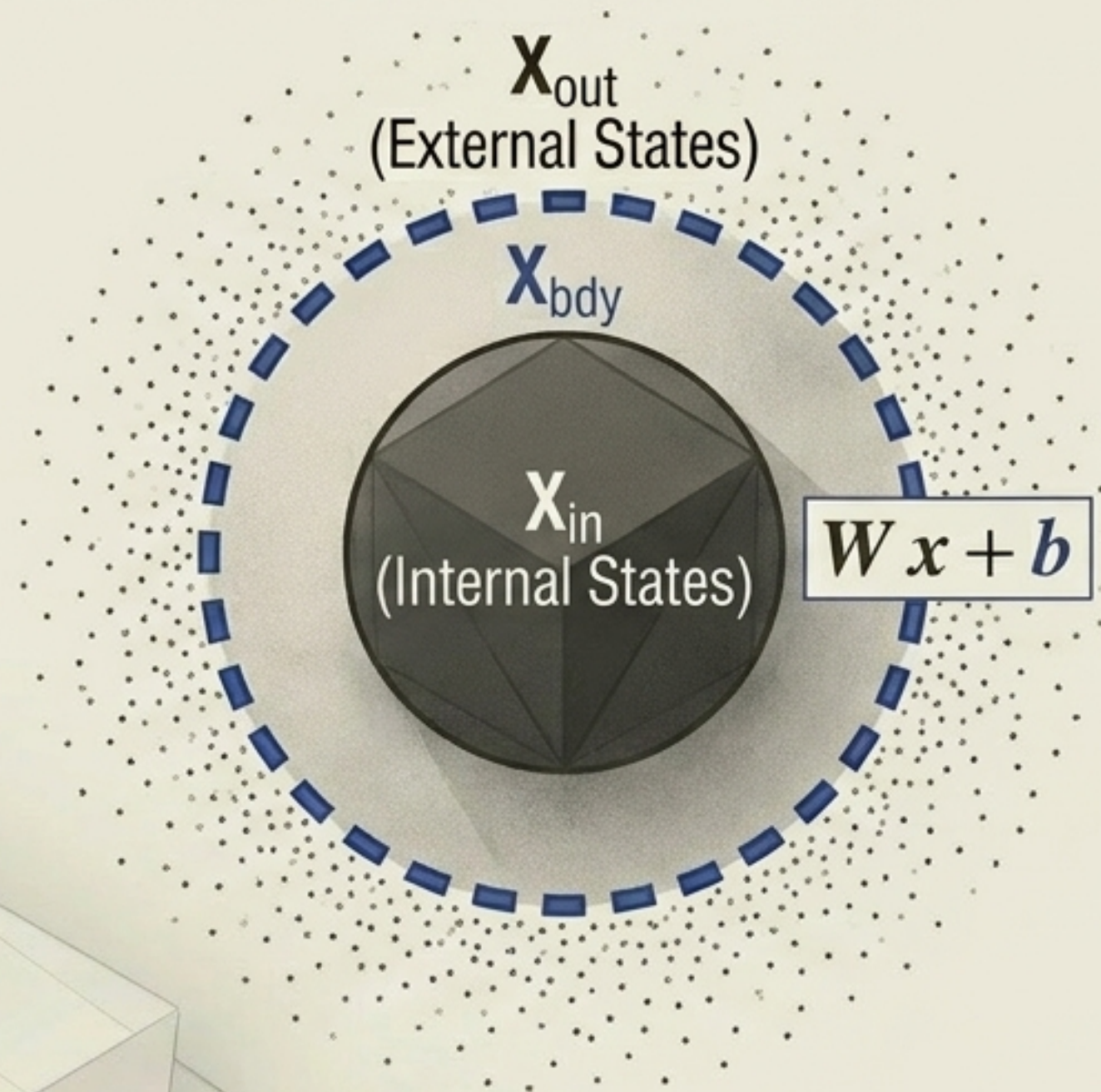

## The Setup:

Internal states are conditionally independent from external states, mediated entirely by the boundary (sensory/active states).

## The Mathematics:

These probabilistic boundaries can be contract given active states.

## The Mathematics:

These probabilistic boundaries can be locally linearized into weights and biases ( $Wx + b$ ).

**The Insight:** The boundary is a weighted linear contract. The predictive self is a deep network of linearized membranes, filtering the world through sequential abstractions.

# Semantic DAGs: Every reduction is a traversal in semantic space.

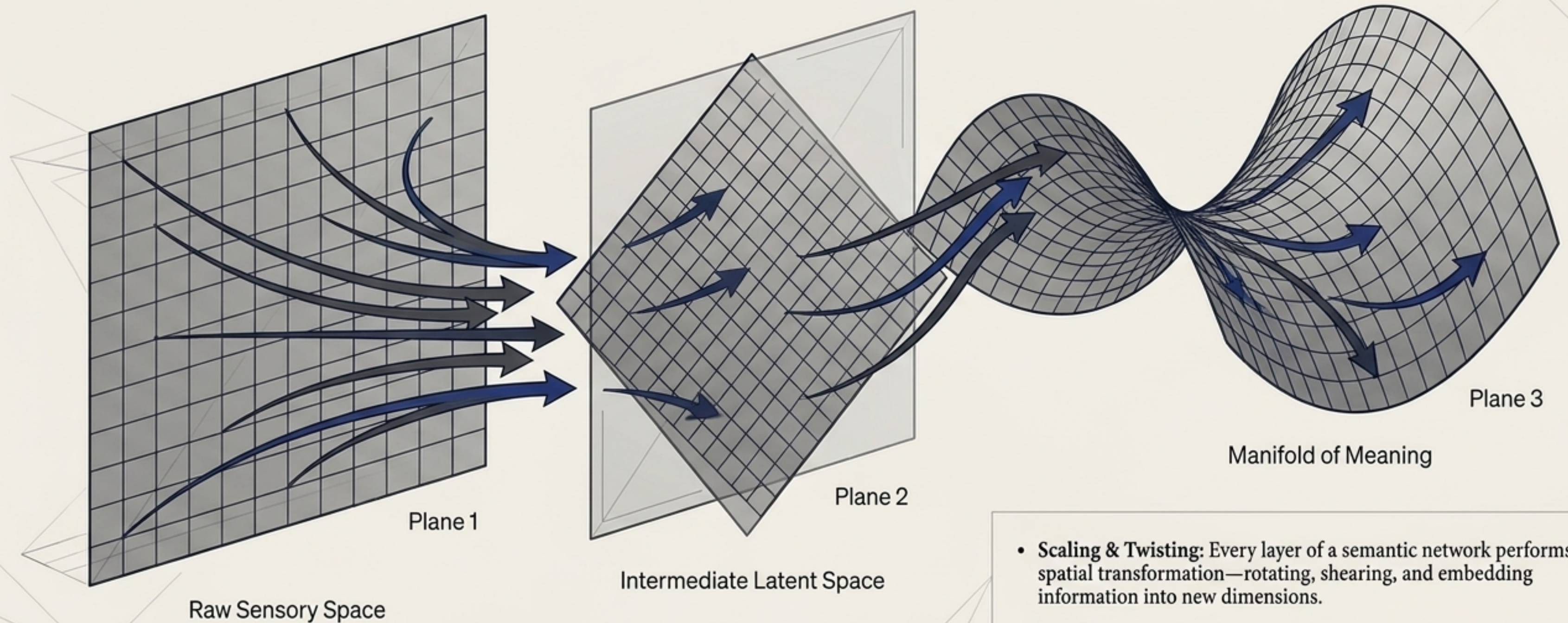

- **Scaling & Twisting:** Every layer of a semantic network performs a spatial transformation—rotating, shearing, and embedding information into new dimensions.
- **Functorial Transport:** Neural computation is not just math; it is functorial transport across a hierarchy of latent spaces.
- **The Result:** Raw sensory input is progressively twisted and folded until the manifolds of meaning align with the axes of action.

# Unistochastic Geometry: The hidden amplitude-level order of cognition.

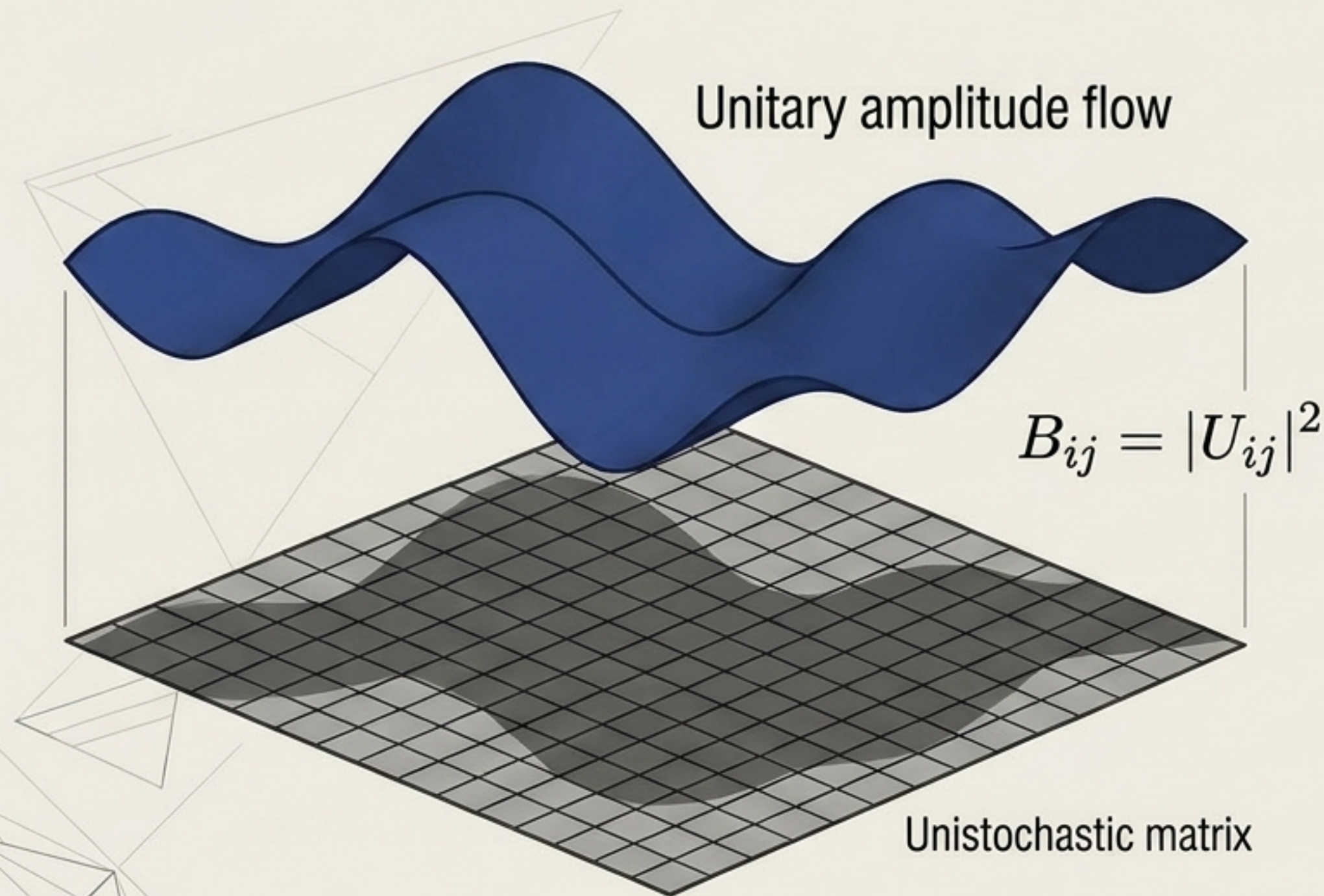

**The Projection:** Semantic transitions (probabilities) are not arbitrary; they are the shadows of amplitude-level unitary flows.

**The Constraint:** A healthy identity evolves along these unistochastic geodesics, maintaining structural coherence.

**The Fracture:** Dissociation or cognitive fracture occurs when transitions step off the manifold, attempting moves that have no underlying unitary witness.

# Spherepop Calculus: The universal geometry of computation

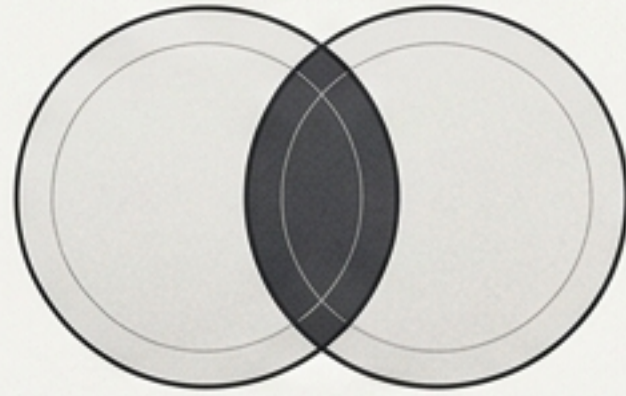

## 1. Merge (The Interaction):

Spatial union or interaction. Represents superposition, algebraic composition, or logic gates.

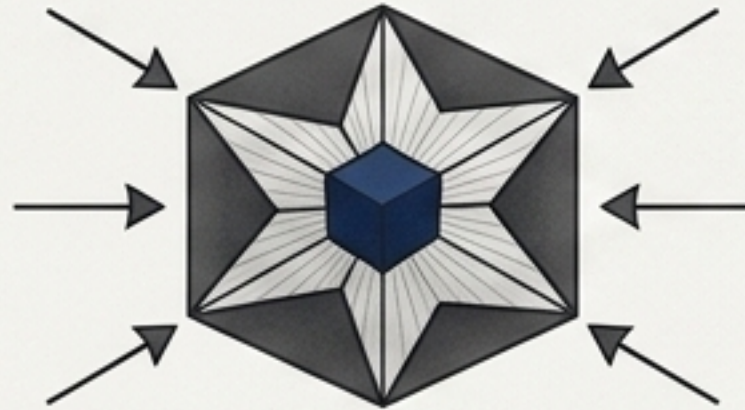

## 2. Collapse (The Abstraction):

Contracting a complex merged region into a scalar or normal form. Represents evaluation or normalization.

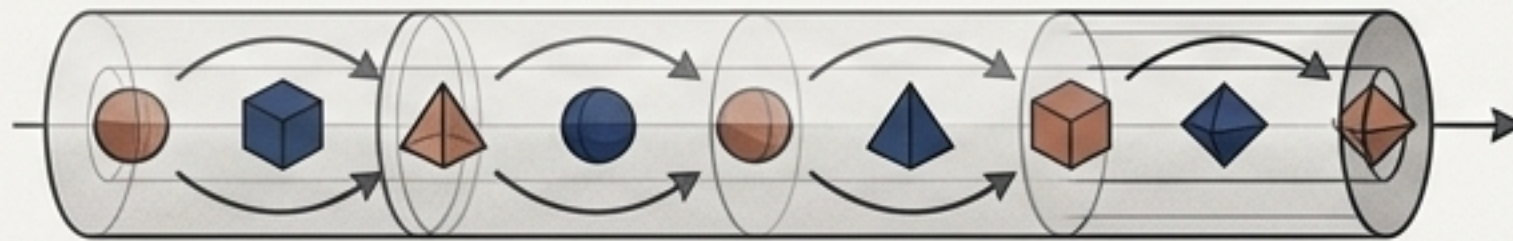

## 3. Pipe (The Flow):

Chaining regions through semantic DAGs. Represents sequential operations and information transport.

**Takeaway:** Spherepop is Turing-complete. It is the geometric process language that seamlessly unifies lambda calculus, Boolean logic, and neural networks.

# The Physics of Computation: The 5D RSVP-Ising Plenum.

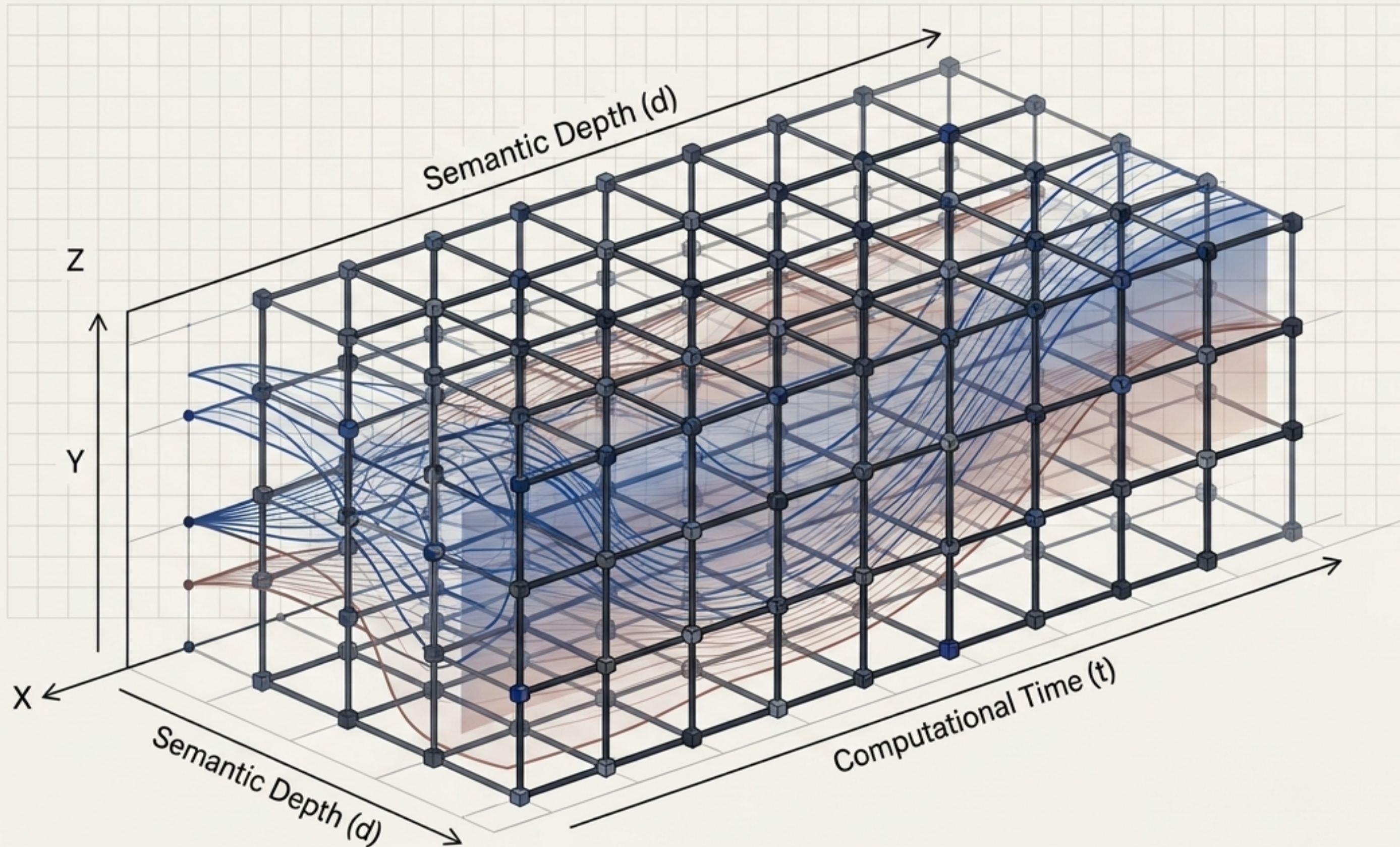

## Microstructure:

Discrete Ising spins encode the exact computational state (Boolean logic / Turing transitions).

## Macrostructure:

RSVP fields (Scalar, Vector, Entropy) shape the broader semantic and physical environment.

## The Physics:

Computation is not an abstract mathematical fiction; it is a physical, energy-descending synchronization occurring in a 5D plenum.

# The Grand Synthesis

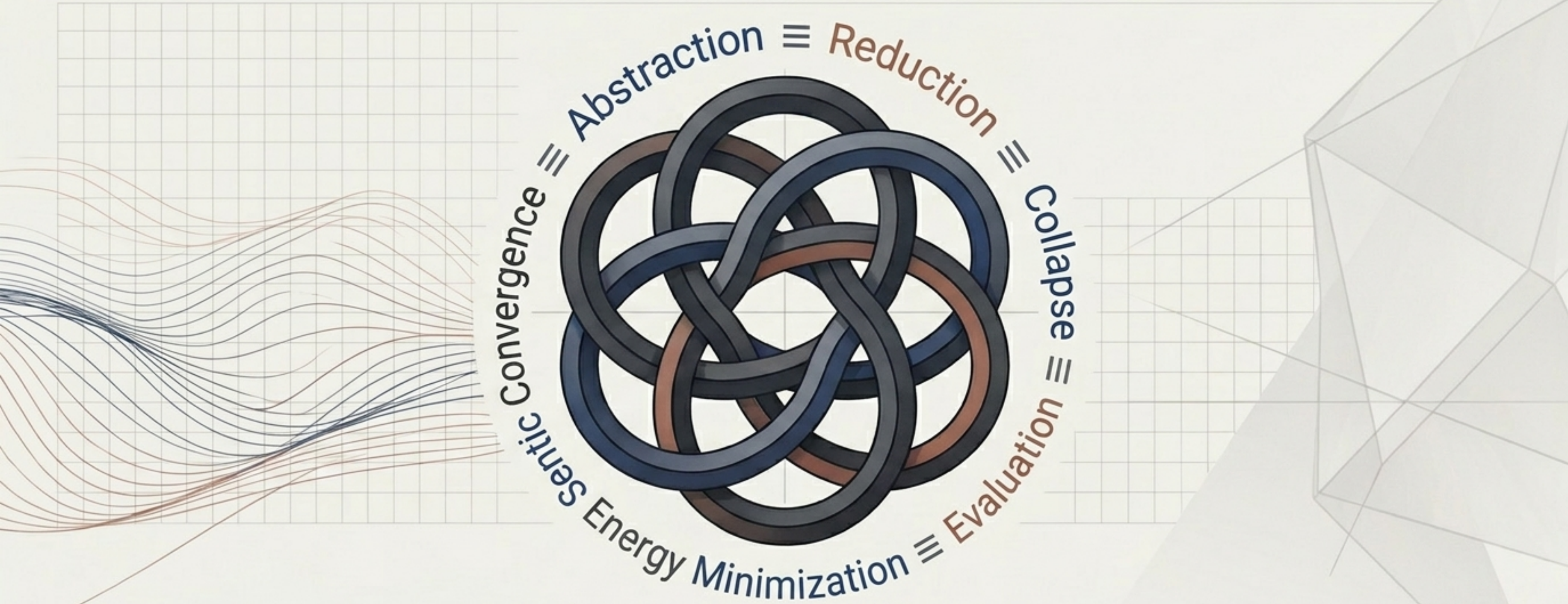

“To compute is to reduce; to reduce is to abstract; to abstract is to fall into alignment with the structure of meaning. Abstraction is the universe computing its own coherent shape.”